

# BATTERY CHANGING SYSTEMS

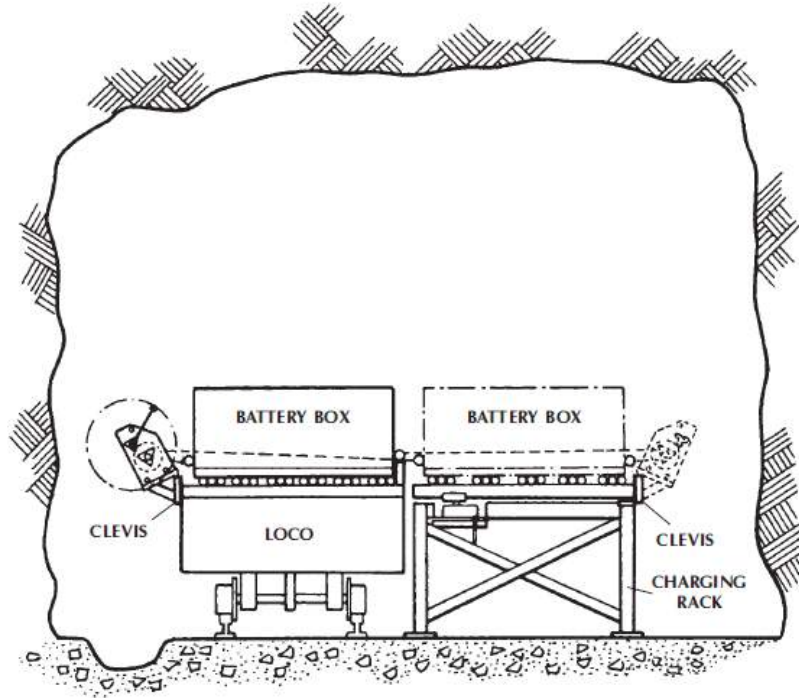

## GENERAL INFORMATION

The Dymot Battery Changing Systems are available in kit form and can be fitted to any battery rack.

The kit consists of four parts:

- Firstly racks for 42 cell and 60 cell batteries.
- Secondly a system of two or three jacks (depending on the size of the battery) for quickly adjusting the height or the level of the battery rack to suit the loco simply by turning one handle.
- Thirdly a winch for pulling the battery from the loco to the rack or vice versa. This winch clips either to the rack or the side of the loco depending on the direction of pull.
- Fourthly winch retaining clevises which must be welded to the loco and the battery racks.

## FEATURES

- Low cost.
- Safety.
- Efficiency.
- No power connections required.
- Simplicity of operating, maintenance and installation.
- Gravity loaded ratchet pawl for extra safety.

**NOTE: The winch is designed to slip into fabricated steel clevises which must be welded to the loco and the battery charging racks. These clevises are purchased separately.**

# BATTERY CHANGING SYSTEMS

GEAR RATIO	ROPE Ø	DRUM CAPACITY	WORKING LENGTH	HANDLE RADIUS	MASS KG
4.5	6 mm	3 m	3 m	228	18

## SPECIFICATION

### PLAN VIEW OF HEIGHT ADJUSTORS

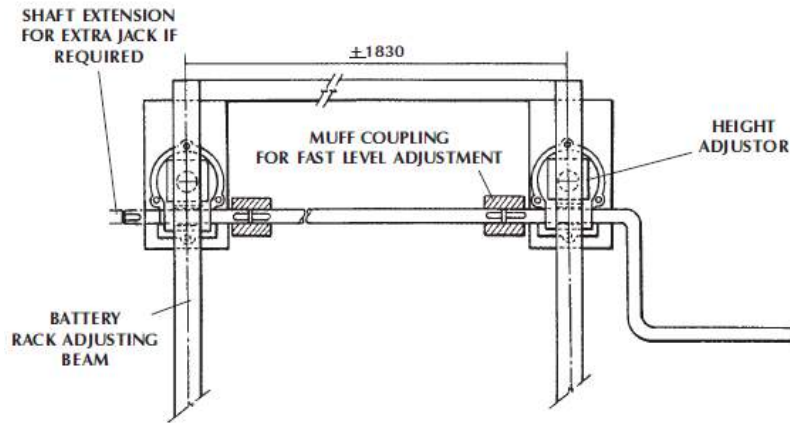

### OUTLINE DIMENSION OF BATTERY CHANGING WINCH

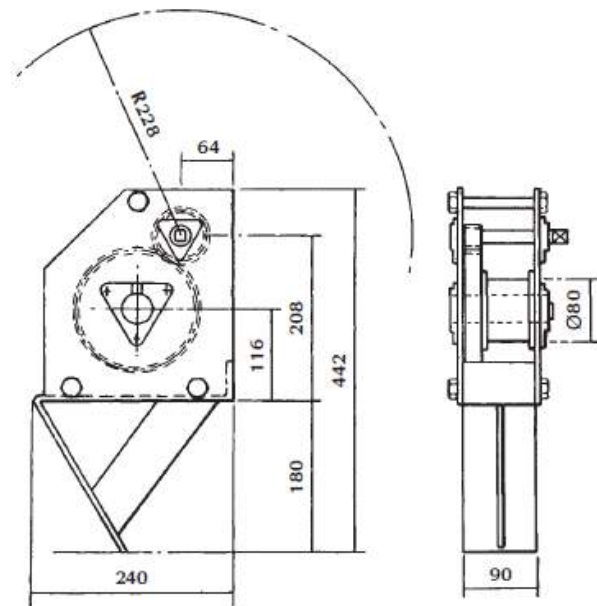

### DIMENSION OF WINCH CLEVIS FOR WELDING TO RACK AND LOCO

